

# KEYLEX 500 WITH RIM BOLT AND STRIKE

## EXTERIOR

## INTERIOR

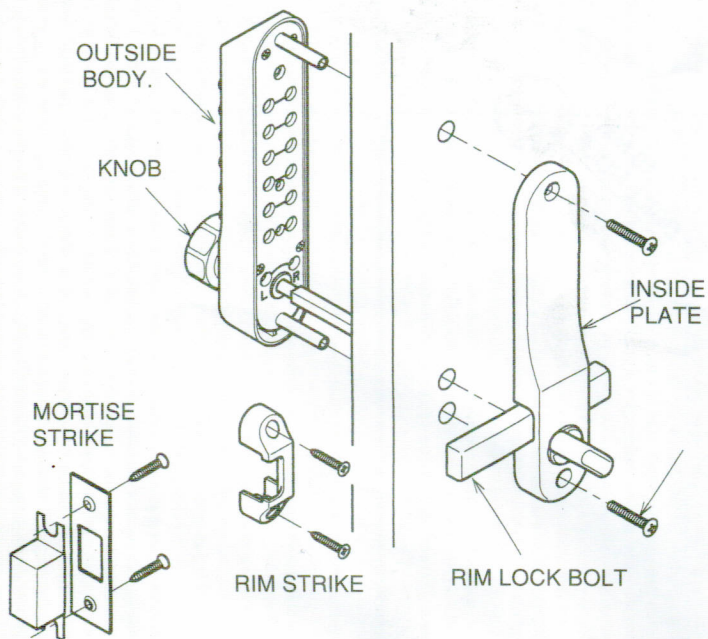

## HAND "R" (EXFACTORY PACKING)

CONFIRM HAND-SET SCREWS IN THE HAND "R" HOLE. HOLD THE KNOB STAY AT "R" POSITION, ROTATE SQ. SPINDLE MARKING "R" TO ADJACENT TO "R" SCREWS.

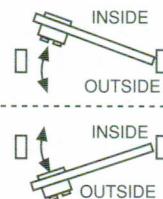

NOTE: HAND SET SCREW MUST BE FIXED TIGHTLY.

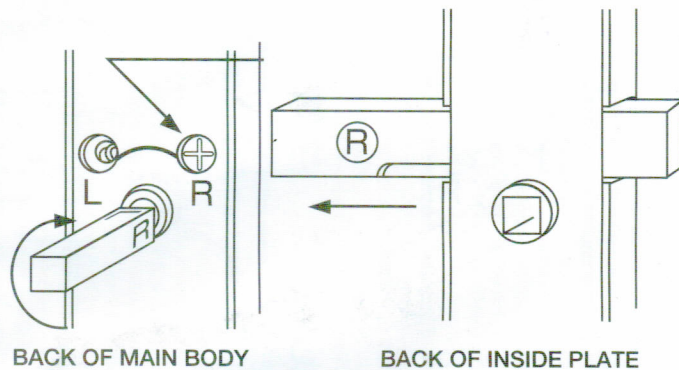

## HOW TO INSTALL:

- ① ENSURE DOOR HANDS PRIOR TO INSTALL THE LOCK. CONVERT HANDS ACCORDINGLY.
- ② PREPARE THE HOLE TO FIX THE LOCK ACCORDING TO THE TEMPLATE AND DRAWING.
- ③ INSTALL MAIN BODY AFTER NOTE DOWN THE CODE NUMBER AND FIX BY THE SCREW TIGHTLY.
- ④ KEEPING THE DOOR OPENING, ENTER CODE NO. TO CONFIRM RIM BOLT WORK SMOOTHLY FROM BOTH SIDE.
  - a. 1ST, USE INSIDE THUMBTURN TO LOCK
  - b. PUSH MEMORY CODE FOR TEST, FROM BUTTON "C" 1ST.
  - c. ROTATE THE KNOB TO UNLOCKING HANDS. CONFIRM RIM DEAD BOLT TRAVEL TO UNLOCK.
  - d. THEN, ROTATE THE KNOB TO 180° DEGREE TO LOCK ENSURING RIM BOLT TRAVEL INTO THE STRIKES.
- ⑤ USE DUST BOX FOR MORTISE STRIKES AND USE OFFSET PIECE TO ADJUST SAME HEIGHT BETWEEN DOOR AND DOOR JAMB SURFACE. (OFFSET PLATE: 2M/MX2PCS& 4.5M/MX3PCS ATTACHED)

## ⊙ MORTISE STRIKE

